



## PRO REMOTE 25 CAPACITANCE PROBE



**OPERATING INSTRUCTIONS**  
**READ THOROUGHLY BEFORE INSTALLING EQUIPMENT**

# TABLE OF CONTENTS

GENERAL SPECIFICATIONS.....	3
1.0 INTRODUCTION.....	4
2.0 APPLICATIONS.....	4
3.0 INSTALLATION.....	4
3.1 Location and Mounting.....	4
3.2 Input Power and Field Wiring.....	5
3.3 Wiring between Probe Head and Electronic Console.....	5
4.0 FAIL-SAFE SELECTION.....	6
4.1 Description.....	6
4.2 Fail-Safe High.....	6
4.3 Fail-Safe Low.....	6
5.0 CALIBRATION.....	7
5.1 Calibration Verification.....	7
5.2 Calibration Procedure.....	7
5.3 Sensitivity Selection.....	8
6.0 TIME DELAY.....	8
7.0 WARRANTY AND CUSTOMER SERVICE.....	8
7.1 LIMITED WARRANTY.....	8
7.2 CUSTOMER SERVICE.....	8
FIGURE 1.1.....	9
FIGURE 1.2.....	10
FIGURE 1.3.....	12
FIGURE 1.4.....	13
FIGURE 2.1.....	14





## PRO REMOTE 25 GENERAL SPECIFICATIONS

<b>Supply:</b>	115 VAC 50/60 Hz (optional 230 VAC model)
<b>Supply Tolerance:</b>	-15% +10%
<b>Load:</b>	2VA
<b>Ambient Temperature: (Electronics)</b>	-40° F to +160° F (-40° C to +70° C)
<b>Sensitivity:</b>	1 picofarad
<b>Approvals:</b>	CSA certified NTRL/C
ISP Probe	Intrinsically Safe for Class 1, Division 1, Groups C & D, Class 2, Division 2 Groups E, F, & G & Type 4X, 5, 12
Electronics Enclosure	Non-Hazardous Location rated Type 4, 5, & 12
<b>Relay Output:</b>	DPDT contacts; 5 Amps 250 VAC
<b>Fail-Safe:</b>	Switch selectable "High" or "Low" level modes
<b>Calibration:</b>	Set when probe is uncovered: COARSE adjust; single turn potentiometer FINE adjust; single turn potentiometer
<b>Status Indicator:</b>	Internal LED indicates material in contact with probe.
<b>Time Delay:</b>	Adjustable from 1 to 15 seconds
<b>Probe Shield:</b>	Automatically compensates for material buildup on the probe
<b>Conduit Entry:</b>	3/4" NPT in ISP Enclosure



## 1.0 INTRODUCTION

The Bin-Master PRO REMOTE 25 is a two piece point level control used to detect the presence or absence of liquids or granular solids. The PRO REMOTE 25 operates on the capacitance principle and incorporates a "Quick Set" feature to simplify calibration. The PRO REMOTE 25 includes switch selectable Fail-Safe output contacts and "Probe Shield" technology for ignoring material build-up.

The PRO REMOTE 25 **does not** use RF and therefore **does not** interfere with nor is susceptible to interference from other devices.

Upon installation the PRO REMOTE 25 is set up with the probe uncovered. The "Quick Set" feature allows simple setup and calibration of the unit to achieve low, medium, or high sensitivity settings. The PRO REMOTE 25 has an adjustable time delay of relay output for covered or uncovered conditions.

## 2.0 APPLICATIONS

2.1 The PRO REMOTE 25 electronics is available in a 115 VAC model or 230 VAC model. Be sure that the rating of the PRO REMOTE 25 is correct for your supply voltage.

2.2 For applications in pressurized vessels up to 1500 PSI, the PRO REMOTE 25 should be mounted with the 3/4" stainless steel coupling.

2.3 Application temperatures for the various probes are:

1. Delrin Sleeved Stainless Steel: ....250 Deg. F
2. Teflon Sleeved Stainless Steel: ....500 Deg. F
3. Flush Mount (Polyethylene): .....180 Deg. F
4. Flush Mount (Teflon): .....450 Deg. F

## 3.0 INSTALLATION

### 3.1 Location and Mounting

The PRO REMOTE PROBE HEAD is designed to mount utilizing either a standard 1- 1/4" NPT coupling or optional 3/4" NPT coupling. When the PROBE HEAD is used with the flush mount probe, the flush mount probe mounts directly to the vessel wall using a 7" diameter bolt circle. Refer to Figures 1.1 through 1.3 for illustrations on installation, mounting options, and different probe combinations.

The PROBE HEAD should be mounted in a position such that the probe itself is not in the direct flow of material.

The vessel on which the PRO REMOTE PROBE HEAD is mounted must be made of metal which acts as part of the capacitive environment. If the vessel is not metal, a suitable metal plate must be installed with the Remote Probe Head.

### 3.2 Input Power and Field Wiring

The PRO REMOTE 25 is available to operate from a 115 VAC or 230 VAC 50/60 Hz supply. Confirm that the PRO REMOTE 25 is the correct model for the supply voltage applied. Field wiring should conform to all national and local electrical codes and any other agency or authority having jurisdiction over the installation.

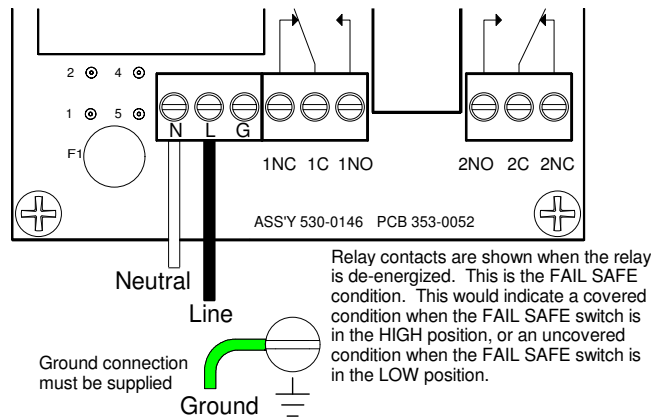

### 3.3 Wiring between Probe Head and Electronic Console

The remote probe is connected to the electronics with a triaxial cable at least 10 feet but not more than 25 feet long. Beldon number 8232 or Alpha number 9850 cable is recommended. The electronics end of the cable is prepared at the factory and should be connected as shown in Figure 1.4 on page 13. The Brown wire connects to the Center Wire terminal, The Blue wire connects to the Inner Shld terminal, and the Green wire connects to the Outer Shld terminal.

The probe head end of the cable should be prepared as shown below. Connect each shield and the center conductor to the appropriate terminal as shown in Figure 1.4. Be sure that there are no loose strands that could short to another terminal or conductor.

**NOTE: Place the cable strain relief nut and rubber grommet on the triax cable before preparing the ends of the cable.**

Strip the outer jacket off 1 3/4 inches away from the end of the cable. Unbraid the strands of the outer shield and then twist them together. Strip the inner teflon jacket off 1 1/2 inches away from the end of the cable. Unbraid the strands of the inner shield and then twist them together. Cut both shields so that they are 3/4 inch long. Strip 1/2 inch of the insulation off of the inner conductor. Each shield and the center conductor should be spaced 3/8 inch apart as shown.

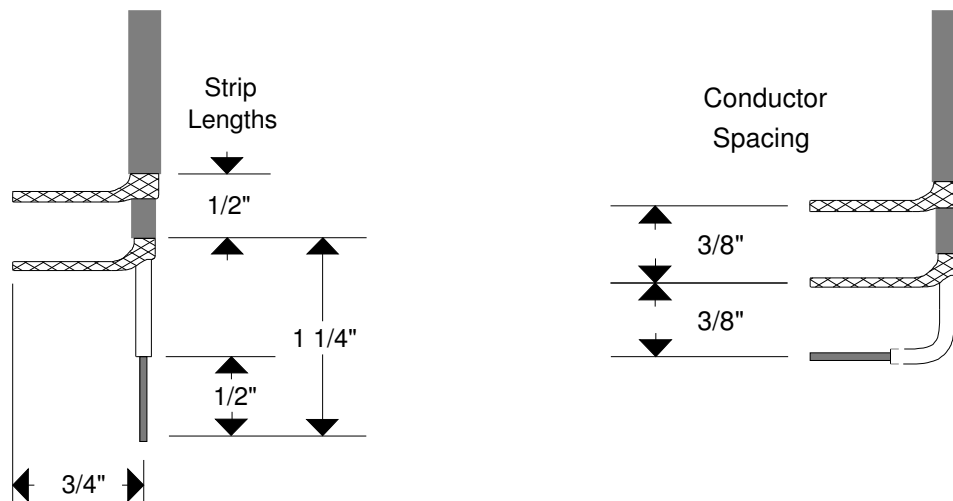

## 4.0 FAIL-SAFE SELECTION

### 4.1 Description

A Fail-Safe condition means that the relay contact positions are set up so that in the event of a power failure, the relay will be de-energized and the contacts will indicate a condition that is deemed safe for the application. (Refer to FIGURE 2.1 for the location of the Fail-Safe selection switch.)

### 4.2 Fail-Safe High

Fail-Safe High means that the relay will be energized when the probe is uncovered and will de-energize when the probe is covered. In this mode, a power failure will cause the relay contacts to indicate that the probe is covered whether it is or not.



### 4.3 Fail-Safe Low

Fail-Safe Low means that the relay will be de-energized when the probe is uncovered and will energize when the probe is covered. In this mode, a power failure will cause the relay contacts to indicate that the probe is uncovered whether it is or not.

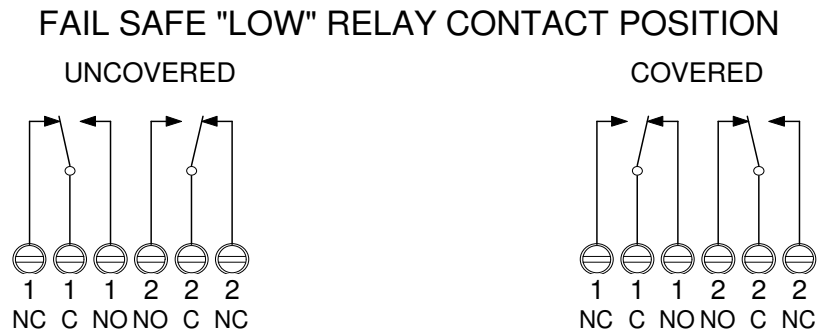

## 5.0 CALIBRATION

The PRO REMOTE 25 Quick Set calibration feature uses two single turn potentiometers making calibration very simple. One potentiometer labeled COARSE is used to compensate for the capacitance of the empty vessel. The other potentiometer labeled FINE is used to set in the desired sensitivity. Refer to FIGURE 2.1 for the location of these potentiometers on the printed circuit board.

**NOTE:***The COARSE and FINE potentiometers are delicate electronic components. Do not use excessive force when adjusting them.*

**NOTE:** *Accurate calibration requires that the appropriate probe be attached to the PRO REMOTE PROBE HEAD and the unit installed in the vessel. The probe must be UNCOVERED and material well below it.*

### 5.1 Calibration Verification

Following calibration adjustment, the sensitivity setting that you have selected should be checked by verifying that the PRO REMOTE 25 senses a covered probe condition with your material.

### 5.2 Calibration Procedure

**NOTE:***Do not use excessive force when adjusting the COARSE and FINE potentiometers.*

1. Turn both the COARSE and FINE potentiometers fully counter clockwise (CCW). The internal COVERED indicator light should be OFF.
2. Turn the COARSE potentiometer slowly clockwise (CW) to the point where the COVERED indicator light just turns ON and stays on.
3. Turn the FINE potentiometer slowly clockwise (CW) until the COVERED indicator light just turns OFF. ( If the COARSE potentiometer has been carefully adjusted, this should occur when the FINE potentiometer is between the 8 and 11 O'clock position.) Now continue to turn the FINE potentiometer clockwise (CW) to the desired sensitivity setting.

HIGH sensitivity: 1/16 turn  
MEDIUM sensitivity: 1/8 turn  
LOW sensitivity: 1/4 to 1/2 turn

### 5.3 Sensitivity Selection

Sensitivity Setting ( typical )	Dielectric Constant of Material
HIGH sensitivity:	4 or less
MEDIUM sensitivity:	4 to 10
LOW sensitivity:	10 or higher

## 6.0 TIME DELAY

The PRO REMOTE has an adjustable time delay up to 15 seconds. This is a time delay for the output to change states from an uncovered to a covered condition and from a covered to an uncovered condition. This time delay affects the DPDT relay contacts. The internal LED (DS1) will immediately respond to a change in covered or uncovered condition regardless of the time delay setting.

Minimum time delay is when the DELAY potentiometer is set fully counter-clockwise. (Refer to FIGURE 2.1 for the location of the DELAY potentiometer.) Maximum time delay is with the DELAY potentiometer set fully clockwise.

***NOTE: Do not use excessive force when adjusting the DELAY potentiometer.***

## **7.0 WARRANTY AND CUSTOMER SERVICE**

### 7.1 Limited Warranty

The manufacturer warrants this equipment for two (2) years according to the following terms:

- 1.) This warranty extends to the original purchaser only and commences on the date of original purchase. The original purchaser must mail to the manufacturer the "Warranty Registration" card to confirm the equipment purchase. Failure to do so may void the warranty.
- 2.) The manufacturer will repair or replace any part of this equipment found to be defective, provided such part is delivered prepaid, to the factory. Manufacturer's obligation is limited to the cost of material and labor to repair or replace and does not include transportation expenses.
- 3.) This warranty shall not apply to any product which has, in our judgment, been tampered with, altered, subject to misuse, neglect or accident. In addition, the warranty does not extend to repairs made necessary by normal wear .
- 4.) This warranty is in lieu of all other warranties, expressed or implied.

### 7.2 Customer Service

Bin Master offers a toll-free Customer Service phone number **1-800-278-4241**. You may call the Customer Service Department for technical and application assistance Monday through Friday from 8:00AM to 5:00PM Central Time. International customers call us at **(402) 434-9102** or reach us via fax at **(402) 434-9133**.





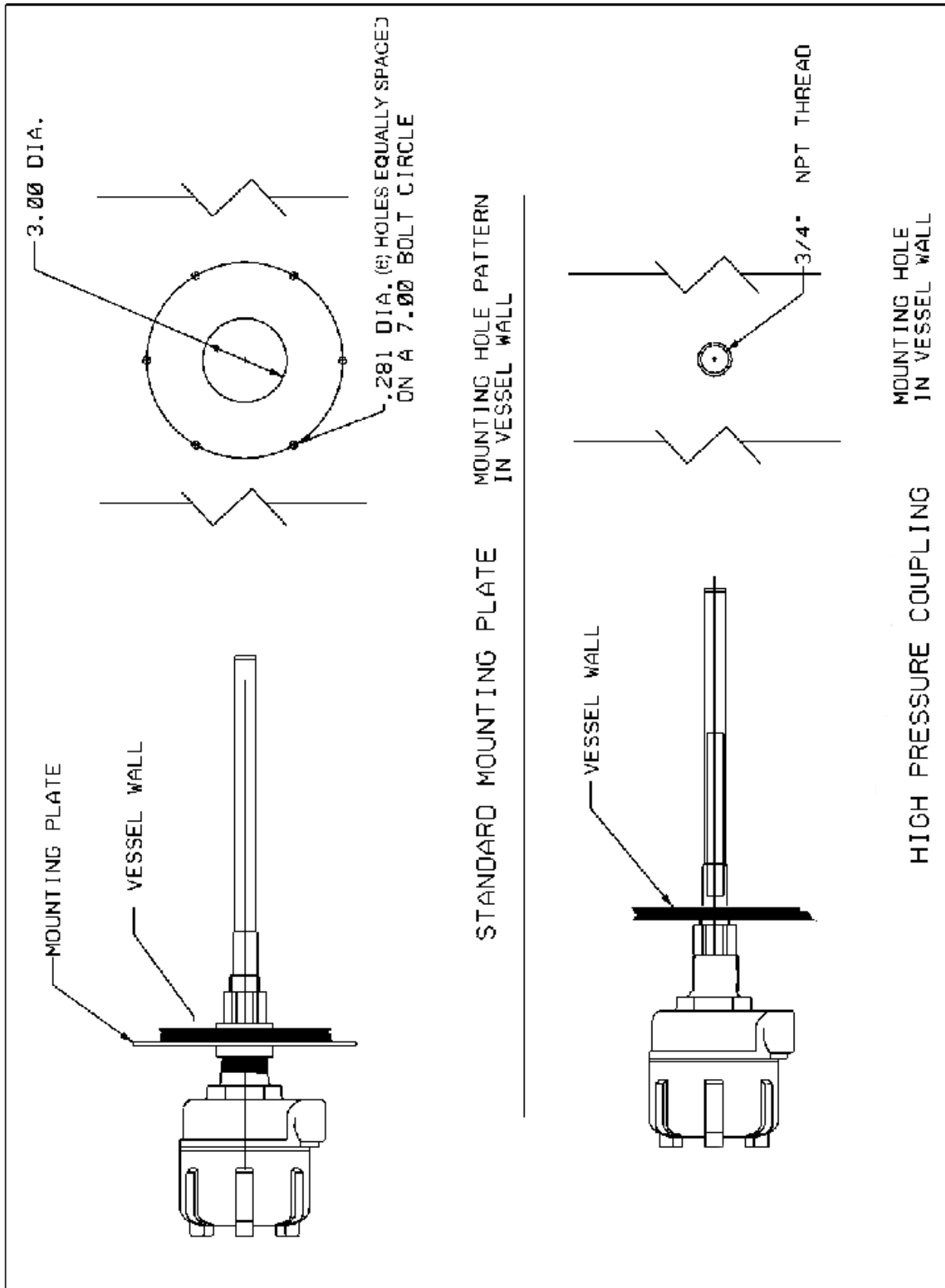

**Figure 1.1**

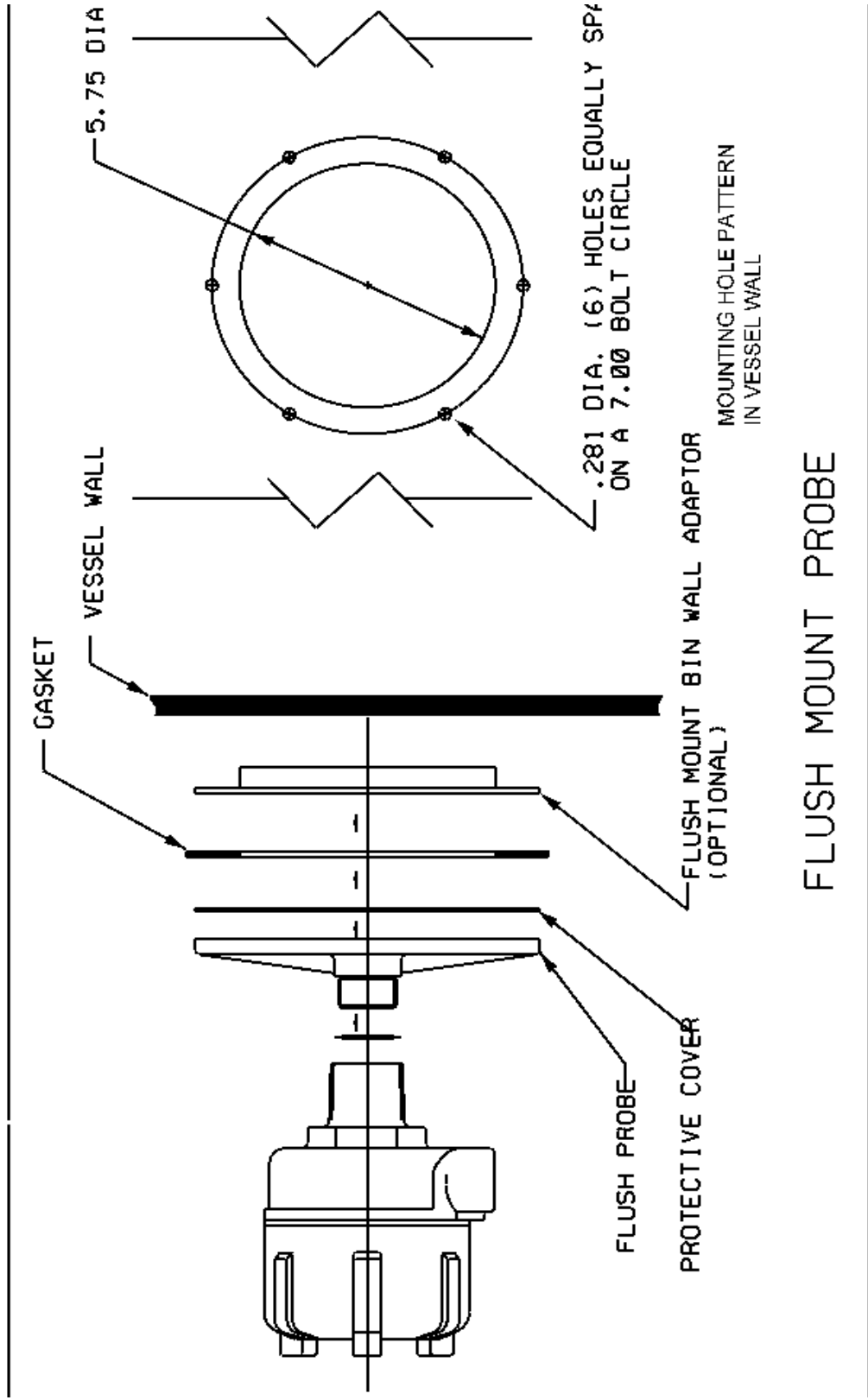

FLUSH MOUNT PROBE

Figure 1.2

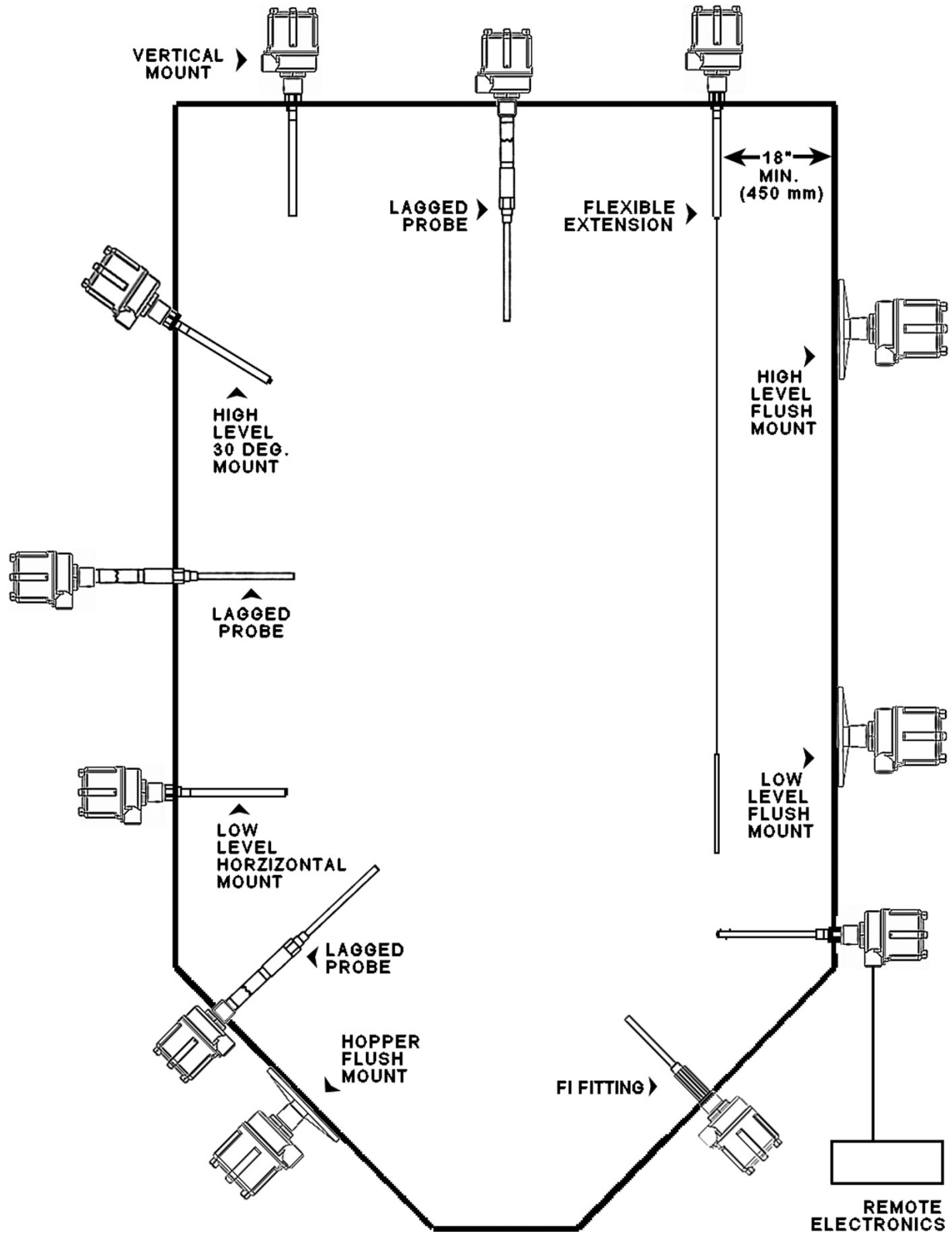
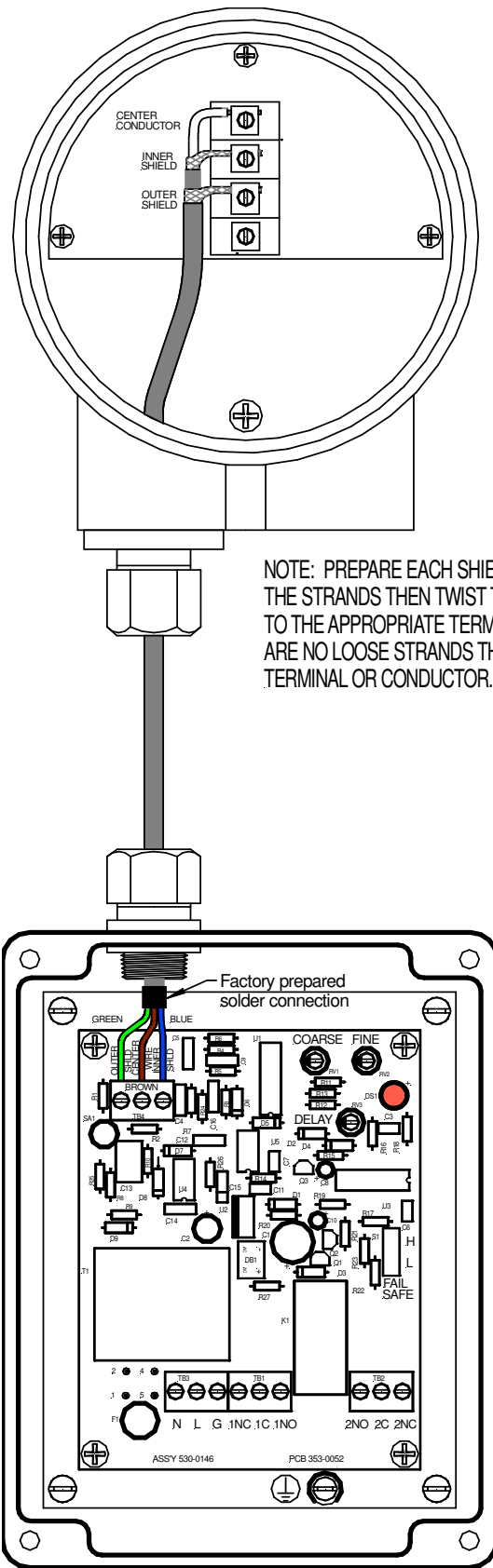

Figure 1.3



NOTE: PREPARE EACH SHIELD CONDUCTOR BY UNBRAIDING THE STRANDS THEN TWIST THEM TOGETHER. CONNECT THEM TO THE APPROPRIATE TERMINAL AS SHOWN. BE SURE THERE ARE NO LOOSE STRANDS THAT COULD SHORT TO ANOTHER TERMINAL OR CONDUCTOR.

Figure 1.4

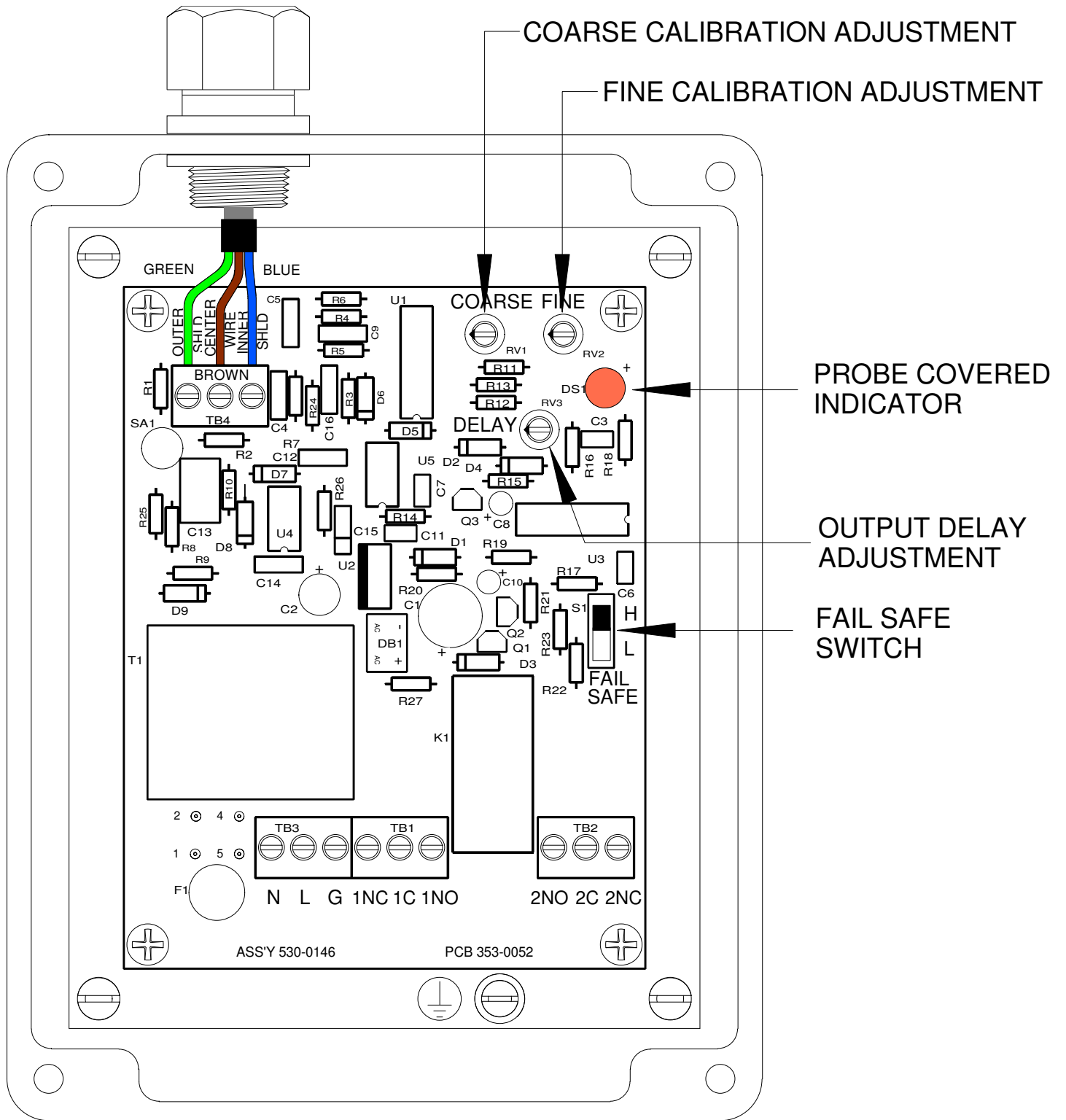
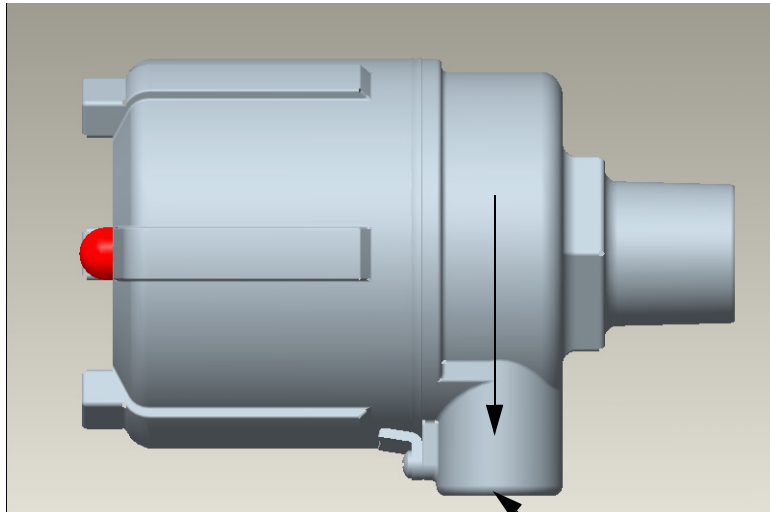
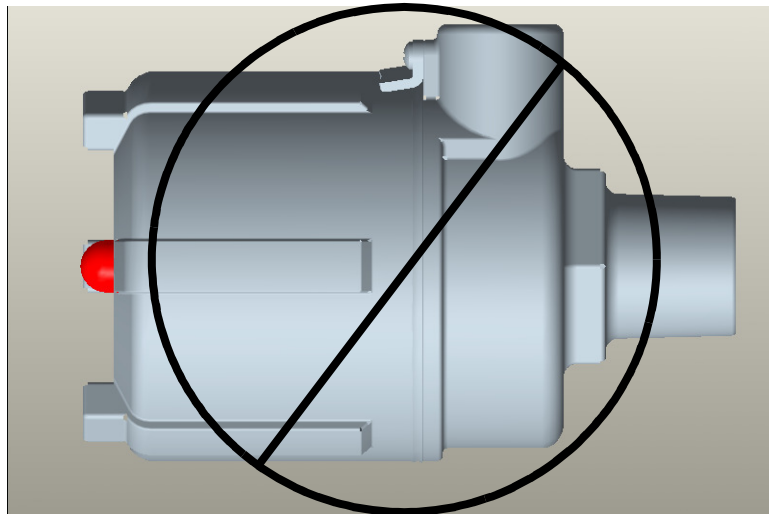

Figure 2.1

# Mounting Instructions



— Always Mount Unit With  
Conduit opening down



## Conduit Seal

When installing this level indicator in environments where it is possible for moisture or moist air to enter the enclosure through the electrical conduit, the conduit opening should be sealed with a duct seal compound or putty appropriate for the purpose.